



TRITON

OUR SECTORS

Terminal operators

Our comprehensive range of Chassis and Roll Trailers provides several options to move heavy or oversized equipment.



OUR SECTORS – TERMINAL OPERATORS

Accessible, reliable equipment to keep busy terminals moving

We offer a range of specialist products designed to help transport equipment within even the busiest container terminals and cargo docks.

Equipment built to last

Our global inventory of specialist products is designed to help transport equipment safely and efficiently.

Ideal for loading and unloading oversized cargo, Triton Roll Trailers and Flatracks can be used to safely transport even the most challenging cargo, including railroad cars, yachts, cables, pipes, and large machinery components.

Our dedicated fleet of Chassis are available across North America. Terminal operators commonly utilize them to transport containers between terminals and shipping facilities. Triton Chassis meet all AAR, TOFC, FMVSS, TTMA, DOT, SAE, ANSI, and ISO specifications.

Our Chassis are constructed from the best quality materials and well-maintained to meet roadability regulations and reduce the amount of downtime that is required to make repairs.

All Triton products comply with our extensive testing and inspection criteria.

Our extensive product inventory consists of new and used intermodal equipment, including Chassis, Roll Trailers, Folding Flatracks, Open Top Containers, Dry Containers, Refrigerated Containers, and ISO Tank Containers.

We have designed creative leasing agreements to fulfill terminal operators' specific operating and financial requirements. Please get in touch with your local Triton representative for more information.

PLEASE NOTE: The following pages showcase a small sample of products in the Triton global inventory. We stock a wide range of products for lease and sale in various conditions. Get in touch with your local Triton representative for more information.



CLASSIFICATION

Lease

Available via Triton's global network of supply locations.

23ft 6in Slider Chassis for 20ft Containers



FEATURES

- Designed for the transport of 20ft ISO containers
- Meets all TOFC, AAR, DOT, FMVSS, ISO, ANSI, SAE and TTMA Specifications
- LED Lights
- 22.5" x 8.25" hub piloted wheels, 11" x 22.5" radials and automatic tire inflation system
- ThermALERT™ – high heat, wheel end warning system, GPS ready
- Rugged, versatile and dependable
- Triton's industry leading new production testing and inspection criteria ensures the highest quality product
- Modern fleet to help reduce "downtime" of chassis repairs
- Dedicated fleet to ensure availability
- Bypass the chassis pools and significantly reduce your daily costs
- Supply throughout North America from an industry leader
- Backed up by Triton's nationwide network of supply locations and dedicated sales and support teams
- Tailored lease terms to meet your company needs

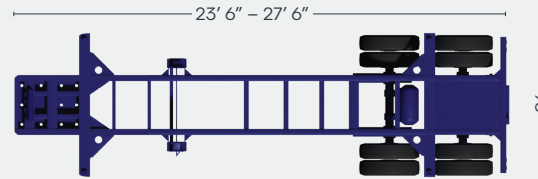

CHASSIS TOP

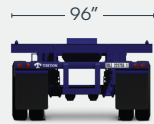

CHASSIS FRONT



CHASSIS SIDE

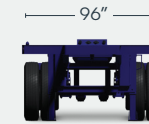

CHASSIS REAR

DIMENSIONS (METRIC/IMPERIAL)

SIZES

Overall Length		
Retracted Position	7,163 mm	23' 6"
Extended Position	8,382 mm	27' 6"
Overall Width		
	2,438 mm	96"
Fifth Wheel Height		
	1,219 mm	48"
Rear Deck Height		
	1,340 mm	52.75"

WEIGHTS

Tare Weight	3,130 kg	6,900 lbs
Gross Vehicle Weight Rating	30,481 kg	67,200 lbs

OTHER

Radial Tires	Yes
LED Lights	Yes

NOTE: The dimensions and door openings of all containers correspond to ISO standards. However, due to production tolerances, a difference in measurement is possible.

DISCLAIMER: Every effort is made to ensure this information is accurate, however Triton does not assume any liability for the accuracy of the information and content provided in marketing or information materials, or for the consequences resulting from using the information and content provided. Triton does not guarantee or claim that said information and content is exhaustive. Claims as to the exhaustive nature of said information and content are excluded. The information and content is only provided for advertising purposes and is non-binding. No explicit or implied warranties or guarantees are made. The container displayed only represents a sample of the entire fleet.

The following items are registered or unregistered service marks in the United States and/or foreign jurisdictions pursuant to applicable intellectual property law and are the property of Triton International Limited and its subsidiaries: Triton® and TAL®.



CLASSIFICATION

Lease

Available via Triton's global network of supply locations.

40ft Gooseneck Chassis for 40ft Containers



FEATURES

- Designed for the transport of 40ft ISO containers
- Meets all TOFC, AAR, DOT, FMVSS, ISO, ANSI, SAE and TTMA Specifications
- LED Lights
- 22.5" x 8.25" hub piloted wheels, 11" x 22.5" radials and automatic tire inflation system
- ThermALERT™ – high heat, wheel end warning system, GPS ready
- Rugged, versatile and dependable
- Triton's industry leading new production testing and inspection criteria ensures the highest quality product
- Modern fleet to help reduce "downtime" of chassis repairs.
- Dedicated fleet to ensure availability
- Bypass the chassis pools and significantly reduce your daily costs
- Supply throughout North America from an industry leader
- Backed up by Triton's nationwide network of supply locations and dedicated sales and support teams
- Tailored lease terms to meet your company needs

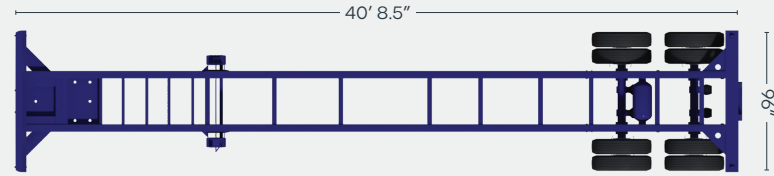

CHASSIS TOP

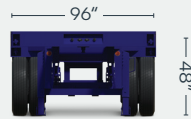

CHASSIS FRONT



CHASSIS SIDE



CHASSIS REAR

DIMENSIONS (METRIC/IMPERIAL)

SIZES

Overall Length	12,408 mm	40' 8.5"
Overall Width	2,438 mm	96"
Fifth Wheel Height	1,219 mm	48"
Rear Deck Height	1,219 mm	48"

WEIGHTS

Tare Weight	3,084 kg	6,800 lbs
Gross Vehicle Weight Rating	30,481 kg	67,200 lbs

OTHER

Radial Tires	Yes
LED Lights	Yes

NOTE: The dimensions and door openings of all containers correspond to ISO standards. However, due to production tolerances, a difference in measurement is possible.

DISCLAIMER: Every effort is made to ensure this information is accurate, however Triton does not assume any liability for the accuracy of the information and content provided in marketing or information materials, or for the consequences resulting from using the information and content provided. Triton does not guarantee or claim that said information and content is exhaustive. Claims as to the exhaustive nature of said information and content are excluded. The information and content is only provided for advertising purposes and is non-binding. No explicit or implied warranties or guarantees are made. The container displayed only represents a sample of the entire fleet.

The following items are registered or unregistered service marks in the United States and/or foreign jurisdictions pursuant to applicable intellectual property law and are the property of Triton International Limited and its subsidiaries: Triton® and TAL®.



CLASSIFICATION

Lease

Available via Triton's global network of supply locations.

40ft-45ft Extendable Gooseneck Chassis



FEATURES

- Designed for the transport of 40ft and 45ft ISO containers
- Meets all TOFC, AAR, DOT, FMVSS, ISO, ANSI, SAE and TTMA Specifications
- LED Lights
- 22.5" x 8.25" hub piloted wheels, 11" x 22.5" radials and automatic tire inflation system
- ThermALERT™ – high heat, wheel end warning system, GPS ready
- Rugged, versatile and dependable
- Triton's industry leading new production testing and inspection criteria ensures the highest quality product
- Dedicated fleet to ensure availability
- Modern fleet to help reduce "downtime" of chassis repairs.
- Bypass the chassis pools and significantly reduce your daily costs
- Supply throughout North America from an industry leader
- Backed up by Triton's nationwide network of supply locations and dedicated sales and support teams
- Tailored lease terms to meet your company needs

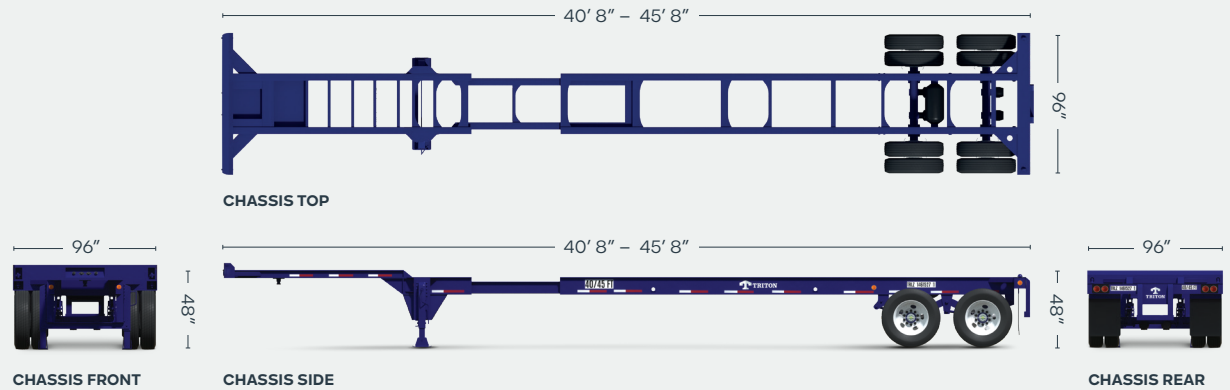

DIMENSIONS (METRIC/IMPERIAL)

SIZES

SIZES		
Overall Length		
Retracted Position	12,395 mm	40' 8"
Extended Position	13,919 mm	45' 8"
Overall Width		
	2,438 mm	96"
Fifth Wheel Height		
	1,219 mm	48"
Rear Deck Height		
	1,219 mm	48"

WEIGHTS

Tare Weight	3,311 kg	7,300 lbs
Gross Vehicle Weight Rating	33,793 kg	74,500 lbs

OTHER

Radial Tires	Yes
LED Lights	Yes

NOTE: The dimensions and door openings of all containers correspond to ISO standards. However, due to production tolerances, a difference in measurement is possible.

DISCLAIMER: Every effort is made to ensure this information is accurate, however Triton does not assume any liability for the accuracy of the information and content provided in marketing or information materials, or for the consequences resulting from using the information and content provided. Triton does not guarantee or claim that said information and content is exhaustive. Claims as to the exhaustive nature of said information and content are excluded. The information and content is only provided for advertising purposes and is non-binding. No explicit or implied warranties or guarantees are made. The container displayed only represents a sample of the entire fleet.

The following items are registered or unregistered service marks in the United States and/or foreign jurisdictions pursuant to applicable intellectual property law and are the property of Triton International Limited and its subsidiaries: Triton® and TAL®.



CLASSIFICATION

Lease

Available via Triton's global network of supply locations.

40ft Roll Trailer



FEATURES

- Available in 40ft length
- Tonnage rating from 60 to 120 tons
- Payload is specifically designed for the movement of products such as high-value cargo such as yachts, rail carriages, steel and cables.
- Triton's industry leading new production testing and inspection criteria ensures the highest quality unit.
- Available globally.
- Flexible lease terms to meet your company needs.
- Backed up by Triton's global network of supply locations and dedicated leasing and support teams.



DIMENSIONS (METRIC/IMPERIAL)

EXTERNAL DIMENSIONS

Length	12,350 mm	40' 6.2"
Width	2,500 mm	8' 2.4"
Height	700 mm	2' 3.6"
Over the wheel set	730 mm	2' 4.7"
Ground clearance	218 mm	0' 8.6"

CAPACITY & WEIGHTS

Capacity	100 tons
Tare	7.5 tons

DISCLAIMER: Every effort is made to ensure this information is accurate, however Triton does not assume any liability for the accuracy of the information and content provided in marketing or information materials, or for the consequences resulting from using the information and content provided. Triton does not guarantee or claim that said information and content is exhaustive. Claims as to the exhaustive nature of said information and content are excluded. The information and content is only provided for advertising purposes and is non-binding. No explicit or implied warranties or guarantees are made. The container displayed only represents a sample of the entire fleet.

The following items are registered or unregistered service marks in the United States and/or foreign jurisdictions pursuant to applicable intellectual property law and are the property of Triton International Limited and its subsidiaries: Triton® and TAL®.



CLASSIFICATION

Lease

Available via Triton's global network of supply locations.

62ft Roll Trailer



FEATURES

- Available in 62ft length
- Supplied with or without 3 rails
- Designed to handle 2 track gauges: Standard Gauge (1,435mm track) and Three Foot Six Inch Gauge (1,067mm track)
- Tonnage rating from 90 to 100 tons
- Payload is specifically designed for the movement of products such as rail-cars and over length cargo
- Triton's industry leading new production testing and inspection criteria ensures the highest quality unit
- Backed up by Triton's global network of supply locations and dedicated leasing and support teams
- Available globally
- Flexible lease terms to meet your company needs

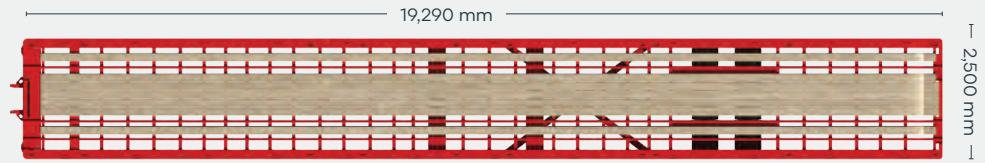

TRAILER TOP

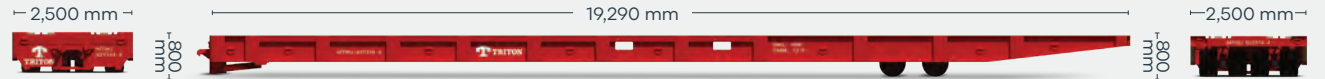

TRAILER FRONT

TRAILER SIDE

TRAILER REAR

DIMENSIONS (METRIC/IMPERIAL)

EXTERNAL DIMENSIONS

Length	19,290 mm	63' 3.4"
Width	2,500 mm	8' 2.4"
Height	800 mm	2' 7.5"
Over the wheel set	850 mm	2' 9.4"
Ground clearance	282 mm	11.1"

CAPACITY & WEIGHTS

Capacity (with 3 rails)	100 tons
Tare (with 3 rails)	12.9 tons

DISCLAIMER: Every effort is made to ensure this information is accurate, however Triton does not assume any liability for the accuracy of the information and content provided in marketing or information materials, or for the consequences resulting from using the information and content provided. Triton does not guarantee or claim that said information and content is exhaustive. Claims as to the exhaustive nature of said information and content are excluded. The information and content is only provided for advertising purposes and is non-binding. No explicit or implied warranties or guarantees are made. The container displayed only represents a sample of the entire fleet.

The following items are registered or unregistered service marks in the United States and/or foreign jurisdictions pursuant to applicable intellectual property law and are the property of Triton International Limited and its subsidiaries: Triton® and TAL®.



Carrier RG15 – Series 55 Clip On



CLASSIFICATION

Lease

Available via Triton's global network of supply locations.



FEATURES

- Ultra-high-efficiency generator enables full power for ISO reefers
- Simple, robust design with familiar operations and maintenance
- Compatible with all reefer machinery manufacturers
- Industry standard, proven 2.2-litre 18.5 KW diesel engine style. EU Stage V compliant, with electronic governor
- CE option included
- 455 litre fuel tank built into all-steel frame
- Standard implementation of enhanced FuelWise™ functionality, a fuel-saving technology that automatically switches the generator set between two speeds via a simple black box controller
- Reduced fuel consumption extends range of distances traveled and reduces carbon footprint
- Pin-mount system with clamp provision (clamp option). For easy attachment and detachment from container box
- Frame and sheet metal components powder-coated for durability and superior corrosion protection
- Carrier full-flow spin-on oil filter with internal bypass filtration
- Integral fuel filter with water separator
- High-efficiency air cleaner
- 12V DC maintenance-free battery and solid state battery charger
- **NEW!** Track and Trace options available

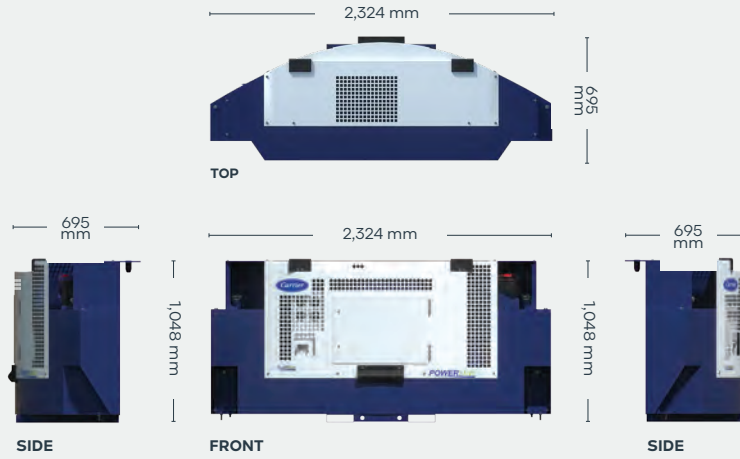

DIMENSIONS (METRIC/IMPERIAL) & SPECIFICATIONS

EXTERNAL DIMENSIONS

Length	2,324 mm	7' 7.5"
Width	695 mm	2' 3.4"
Height	1,048 mm	3' 5.2"

ENGINE

V2203L-DI-E4B, 4-cylinder, water-cooled, 2.2 litre direct-injection diesel engine

FUEL TYPE & CAPACITY

Fuel Type	Diesel	
Fuel Tank	455 liter	120 gal

BATTERY

Type	12V DC maintenance-free battery
-------------	---------------------------------

APPROXIMATE WEIGHT

Less fuel	875 kg
------------------	--------

NOTE: The dimensions and door openings of all containers correspond to ISO standards. However, due to production tolerances, a difference in measurement is possible.

DISCLAIMER: Every effort is made to ensure this information is accurate, however Triton does not assume any liability for the accuracy of the information and content provided in marketing or information materials, or for the consequences resulting from using the information and content provided. Triton does not guarantee or claim that said information and content is exhaustive. Claims as to the exhaustive nature of said information and content are excluded. The information and content is only provided for advertising purposes and is non-binding. No explicit or implied warranties or guarantees are made. The container displayed only represents a sample of the entire fleet. The following items are registered or unregistered service marks in the United States and/or foreign jurisdictions pursuant to applicable intellectual property law and are the property of Triton International Limited and its subsidiaries: Triton® and TAL®.



CLASSIFICATION

Lease

Available via Triton's global network of supply locations.

Thermo King SG-5000 Clip On



FEATURES

- Ensure total product protection, time after time
- The intelligent controls system allows both quick local diagnostic and full monitoring over telematics
- Compatible with all reefer machinery manufacturers
- Proven reliability and durability
- Exceed the power requirements for any ISO reefer
- Surpasses all North American emission compliance requirements including: EPA, CARB, Environment Canada and EEA
- Auto restart
- Built to last and perform – lowest total cost of ownership (TCO)
- Automated pre-trip testing
- Data logging of events, alarms and messages
- Delivered in both undermount and clip-on design
- Eco power with two speed technology
- Pin-mount system with clamp provision (clamp option). For easy attachment and detachment from container box
- **NEW!** Track and Trace options available

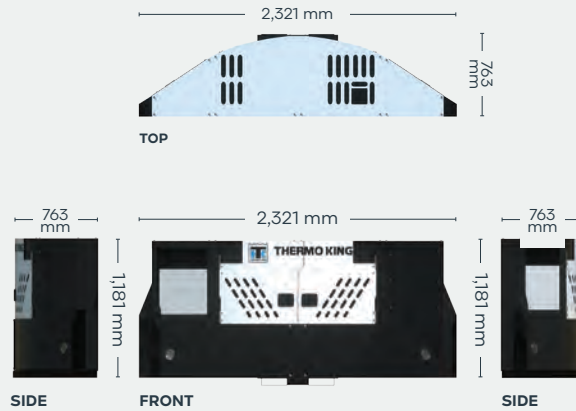

DIMENSIONS (METRIC/IMPERIAL) & SPECIFICATIONS

EXTERNAL DIMENSIONS

Length	2,321 mm	7' 7.3"
Width	763 mm	2' 6.0"
Height	1,181 mm	3' 10.5"

ENGINE

Thermo King diesel engine compliant with EPA Tier 4 and CARB regulations

FUEL TYPE

No. 2 diesel (under normal conditions)
No. 1 diesel (cold weather fuel)

SPEED & POWER

Rotational Speed	1500 ±25rpm / 1800 ±25rpm
Generator Output	460/230Vac, 3Phase, 60Hz
Power Apparent	15kW
Power Rotational	18.75 kVA
Speed	1800rpm
Electrical System	SG+ microprocessor controller
Battery	12V, 925CCA

FUEL TANK

Included in all models

SGCO	473 litres	125gal
SGCM	302l or 198l	80gal or 50gal
SGSM	302l or 198l	80gal or 50gal

WEIGHT - LESS FUEL

SGCO	871kg	1920lbs
SGCM		
50gal tank	653kg	1440lbs
80gal tank	680kg	1500lbs

NOTE: The dimensions and door openings of all containers correspond to ISO standards. However, due to production tolerances, a difference in measurement is possible.

DISCLAIMER: Every effort is made to ensure this information is accurate, however Triton does not assume any liability for the accuracy of the information and content provided in marketing or information materials, or for the consequences resulting from using the information and content provided. Triton does not guarantee or claim that said information and content is exhaustive. Claims as to the exhaustive nature of said information and content are excluded. The information and content is only provided for advertising purposes and is non-binding. No explicit or implied warranties or guarantees are made. The container displayed only represents a sample of the entire fleet.

The following items are registered or unregistered service marks in the United States and/or foreign jurisdictions pursuant to applicable intellectual property law and are the property of Triton International Limited and its subsidiaries: Triton® and TAL®.



HERE. THERE. EVERYWHERE

We supply the world

Triton is the largest lessor of intermodal containers in the world with over 7 million TEU of containers. Our services are available in 89 countries around the globe. So, no matter where you need containers, we'll have them nearby. To find your nearest Triton Container Sales manager visit www.tritoncontainer.com.



**Global inventory of
cargoworthy containers
for lease and sale.**



**Unrivalled container
supply at competitive
prices.**



**Outstanding and
highly responsive
customer services.**



**Global network of 20 offices
and 3 independent agencies
across 16 countries.**



**Equipment
built to the
highest quality.**



**Our size, strength and reliability
make us the go-to supplier of
intermodal shipping containers.**



TRITON

We're the biggest for a reason, contact our friendly experts and experience Triton's world-leading service and cost savings today. Imagine what we can do together.

www.tritoncontainer.com