



TRITON

OUR SECTORS

Trucking

Our extensive range of Chassis and Gensets offer a variety of solutions for moving equipment.



OUR SECTORS – TRUCKING

Keeping businesses moving

The Triton range of Chassis, Gensets, and Shipping Containers offers container trucking companies various options to move equipment within even the busiest container terminals to off-dock and inland locations.

Leasing Chassis

We offer our trucking customers various lease options designed to help them handle uncertain freight demand, balance trade flows, manage seasonality, and finance their growth.

Buying Chassis

Our in-house equipment sales group, Triton Container Sales (TCS), manages the retirement process of our used equipment, including Chassis. We combine local knowledge with our global resources to offer a range of used Chassis in various conditions at the best possible prices.

We also buy and sell new and used equipment acquired from third parties. Please get in touch with your local representative for more information.

PLEASE NOTE: The following pages showcase a small sample of products in the Triton global inventory. We stock a wide range of products for lease and sale in various conditions. Get in touch with your local Triton representative for more information.



CLASSIFICATION

For Sale: Used

Available via Triton's global network of supply locations.

23ft 6in Used Slider Chassis for 20ft Containers



FEATURES

- Designed for the transport of 20ft ISO containers
- Rugged, versatile and dependable
- Chassis available in "road worthy" condition with current FHWA inspection certificate
- Alternatively can be sold in "as is" condition, for those looking to do their own repairs or tire swaps
- In most cases chassis can be made available for survey, or pictures can be provided on request
- Backed up by Triton's global network of supply locations and dedicated sales and support teams
- Supply throughout North America from an industry leader

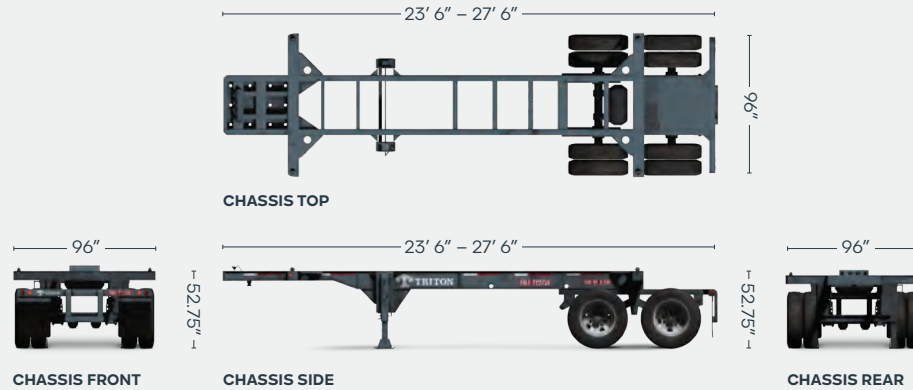

DIMENSIONS (METRIC/IMPERIAL)

SIZES

Overall Length		
Retracted Position	7,163 mm	23' 6"
Extended Position	8,382 mm	27' 6"
Overall Width		
	2,438 mm	96"
Fifth Wheel Height		
	1,219 mm	48"
Rear Deck Height		
	1,340 mm	52.75"

WEIGHTS

Tare Weight	3,130 kg	6,900 lbs
Gross Vehicle Weight Rating	30,481 kg	67,200 lbs

OTHER

Radial Tires	Yes
LED Lights	Yes

NOTE: The dimensions and door openings of all containers correspond to ISO standards. However, due to production tolerances, a difference in measurement is possible.

DISCLAIMER: Every effort is made to ensure this information is accurate, however Triton does not assume any liability for the accuracy of the information and content provided in marketing or information materials, or for the consequences resulting from using the information and content provided. Triton does not guarantee or claim that said information and content is exhaustive. Claims as to the exhaustive nature of said information and content are excluded. The information and content is only provided for advertising purposes and is non-binding. No explicit or implied warranties or guarantees are made. The container displayed only represents a sample of the entire fleet.

The following items are registered or unregistered service marks in the United States and/or foreign jurisdictions pursuant to applicable intellectual property law and are the property of Triton International Limited and its subsidiaries: Triton® and TAL®.



CLASSIFICATION

Lease

Available via Triton's global network of supply locations.

40ft Gooseneck Chassis for 40ft Containers



FEATURES

- Designed for the transport of 40ft ISO containers
- Meets all TOFC, AAR, DOT, FMVSS, ISO, ANSI, SAE and TTMA Specifications
- LED Lights
- 22.5" x 8.25" hub piloted wheels, 11" x 22.5" radials and automatic tire inflation system
- ThermALERT™ – high heat, wheel end warning system, GPS ready
- Rugged, versatile and dependable
- Triton's industry leading new production testing and inspection criteria ensures the highest quality product
- Modern fleet to help reduce "downtime" of chassis repairs.
- Dedicated fleet to ensure availability
- Bypass the chassis pools and significantly reduce your daily costs
- Supply throughout North America from an industry leader
- Backed up by Triton's nationwide network of supply locations and dedicated sales and support teams
- Tailored lease terms to meet your company needs

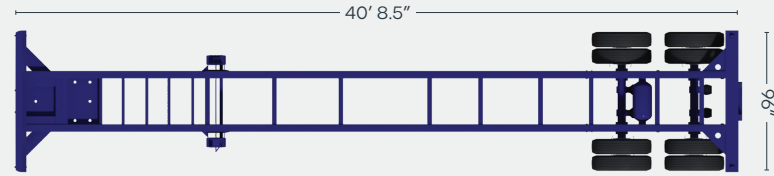

CHASSIS TOP

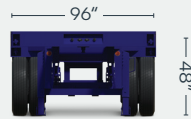

CHASSIS FRONT



CHASSIS SIDE



CHASSIS REAR

DIMENSIONS (METRIC/IMPERIAL)

SIZES

Overall Length	12,408 mm	40' 8.5"
Overall Width	2,438 mm	96"
Fifth Wheel Height	1,219 mm	48"
Rear Deck Height	1,219 mm	48"

WEIGHTS

Tare Weight	3,084 kg	6,800 lbs
Gross Vehicle Weight Rating	30,481 kg	67,200 lbs

OTHER

Radial Tires	Yes
LED Lights	Yes

NOTE: The dimensions and door openings of all containers correspond to ISO standards. However, due to production tolerances, a difference in measurement is possible.

DISCLAIMER: Every effort is made to ensure this information is accurate, however Triton does not assume any liability for the accuracy of the information and content provided in marketing or information materials, or for the consequences resulting from using the information and content provided. Triton does not guarantee or claim that said information and content is exhaustive. Claims as to the exhaustive nature of said information and content are excluded. The information and content is only provided for advertising purposes and is non-binding. No explicit or implied warranties or guarantees are made. The container displayed only represents a sample of the entire fleet.

The following items are registered or unregistered service marks in the United States and/or foreign jurisdictions pursuant to applicable intellectual property law and are the property of Triton International Limited and its subsidiaries: Triton® and TAL®.



CLASSIFICATION

Lease

Available via Triton's global network of supply locations.

40ft-45ft Extendable Gooseneck Chassis



FEATURES

- Designed for the transport of 40ft and 45ft ISO containers
- Meets all TOFC, AAR, DOT, FMVSS, ISO, ANSI, SAE and TTMA Specifications
- LED Lights
- 22.5" x 8.25" hub piloted wheels, 11" x 22.5" radials and automatic tire inflation system
- ThermALERT™ – high heat, wheel end warning system, GPS ready
- Rugged, versatile and dependable
- Triton's industry leading new production testing and inspection criteria ensures the highest quality product
- Dedicated fleet to ensure availability
- Modern fleet to help reduce "downtime" of chassis repairs.
- Bypass the chassis pools and significantly reduce your daily costs
- Supply throughout North America from an industry leader
- Backed up by Triton's nationwide network of supply locations and dedicated sales and support teams
- Tailored lease terms to meet your company needs

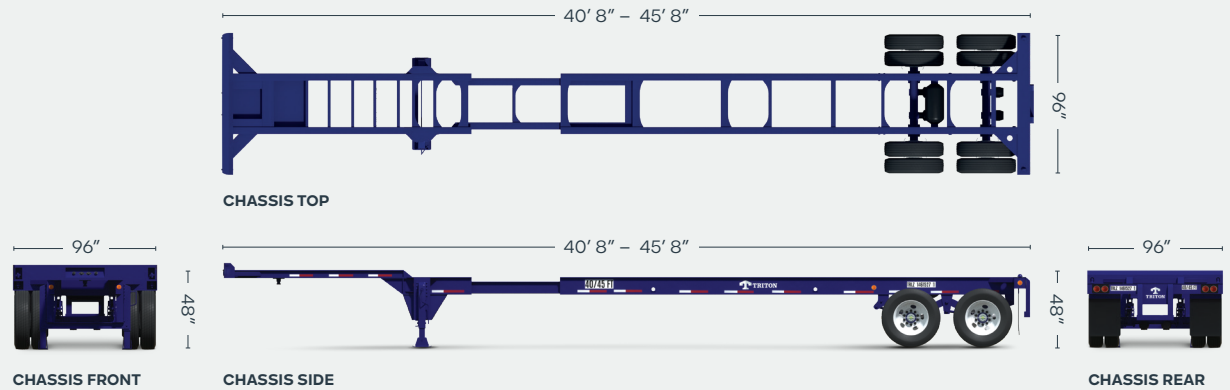

DIMENSIONS (METRIC/IMPERIAL)

SIZES

Overall Length		
Retracted Position	12,395 mm	40' 8"
Extended Position	13,919 mm	45' 8"
Overall Width	2,438 mm	96"
Fifth Wheel Height	1,219 mm	48"
Rear Deck Height	1,219 mm	48"

WEIGHTS

Tare Weight	3,311 kg	7,300 lbs
Gross Vehicle Weight Rating	33,793 kg	74,500 lbs

OTHER

Radial Tires	Yes
LED Lights	Yes

NOTE: The dimensions and door openings of all containers correspond to ISO standards. However, due to production tolerances, a difference in measurement is possible.

DISCLAIMER: Every effort is made to ensure this information is accurate, however Triton does not assume any liability for the accuracy of the information and content provided in marketing or information materials, or for the consequences resulting from using the information and content provided. Triton does not guarantee or claim that said information and content is exhaustive. Claims as to the exhaustive nature of said information and content are excluded. The information and content is only provided for advertising purposes and is non-binding. No explicit or implied warranties or guarantees are made. The container displayed only represents a sample of the entire fleet.

The following items are registered or unregistered service marks in the United States and/or foreign jurisdictions pursuant to applicable intellectual property law and are the property of Triton International Limited and its subsidiaries: Triton® and TAL®.



20ft Dry Container



CLASSIFICATION

Lease

Available via Triton's global network of supply locations.



FEATURES

- Manufactured with rust resistant corten steel
- Secure and weatherproof, with vents to allow airflow
- Resistant to damage and corrosion
- Superior paint systems
- Triton's industry leading new production testing and inspection criteria ensures the highest quality container
- Incredibly versatile
- Backed up by Triton's global network of supply locations and dedicated leasing and support teams
- Available globally
- IICL-6 repair criteria saves cost at off-hire
- Damage Protection Plan available to reduce costs and time at off-hire
- Flexible lease terms to meet your company needs



CONTAINER ROOF

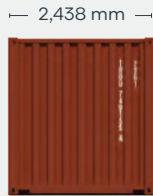

CONTAINER FRONT



CONTAINER SIDE

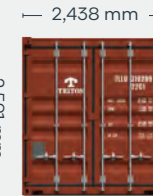

CONTAINER REAR

DIMENSIONS (METRIC/IMPERIAL)

EXTERNAL DIMENSIONS

Length	6,058 mm	19' 10.5"
Width	2,438 mm	8' 0.0"
Height	2,591 mm	8' 6.0"

INTERNAL DIMENSIONS

Length	5,898 mm	19' 4.2"
Width	2,352 mm	7' 8.6"
Height	2,393 mm	7' 10.2"

DOOR OPENING

Width	2,340 mm	7' 8.1"
Height	2,280 mm	7' 5.8"

CAPACITY & WEIGHTS

Inside Cubic Capacity	33.2 m ³	1172 ft ³
Max Gross	30,480 kg	67,200 lbs
Payload	28,380 kg	62,570 lbs
Tare	2,100 kg	4,630 lbs

NOTE: The dimensions and door openings of all containers correspond to ISO standards. However, due to production tolerances, a difference in measurement is possible.

DISCLAIMER: Every effort is made to ensure this information is accurate, however Triton does not assume any liability for the accuracy of the information and content provided in marketing or information materials, or for the consequences resulting from using the information and content provided. Triton does not guarantee or claim that said information and content is exhaustive. Claims as to the exhaustive nature of said information and content are excluded. The information and content is only provided for advertising purposes and is non-binding. No explicit or implied warranties or guarantees are made. The container displayed only represents a sample of the entire fleet.

The following items are registered or unregistered service marks in the United States and/or foreign jurisdictions pursuant to applicable intellectual property law and are the property of Triton International Limited and its subsidiaries: Triton® and TAL®.



CLASSIFICATION

For Sale: Used

Available via Triton's global network of supply locations.

40ft Used Dry Container



FEATURES

- Available in a range of conditions to suit all needs, from cargo transportation to secure domestic storage
- Generally 11-15 years old when retired from service
- Constructed from rugged corten steel
- Durable and secure, with vents to allow airflow
- Resistant to damage and corrosion
- A variety of options available
- Incredibly versatile and suitable for customers to modify into a wide range of applications
- Available globally
- Backed up by Triton's global network of supply locations and dedicated sales and support teams
- Also available for direct delivery to buyer's facilities, providing significant cost savings on transport

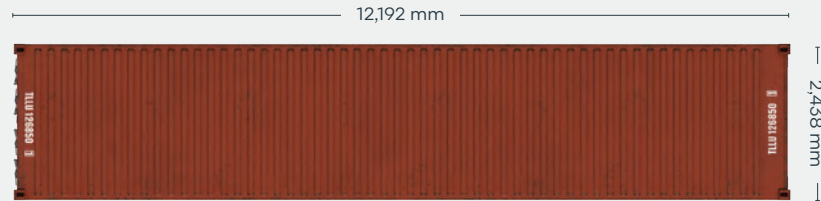

CONTAINER ROOF

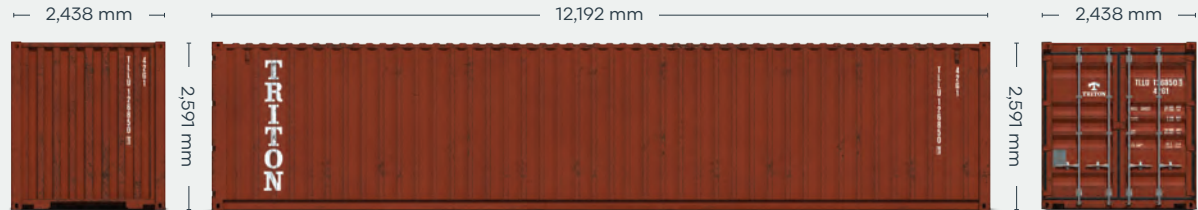

CONTAINER FRONT

CONTAINER SIDE

CONTAINER REAR

DIMENSIONS (METRIC/IMPERIAL)

EXTERNAL DIMENSIONS

Length	12,192 mm	40' 0.0"
Width	2,438 mm	8' 0.0"
Height	2,591 mm	8' 6.0"

INTERNAL DIMENSIONS

Length	12,032 mm	39' 5.7"
Width	2,352 mm	7' 8.6"
Height	2,393 mm	7' 10.2"

DOOR OPENING

Width	2,340 mm	7' 8.1"
Height	2,280 mm	7' 5.8"

CAPACITY & WEIGHTS

Inside Cubic Capacity	67.7 m ³	2390 ft ³
Max Gross	30,480–32,500 kg	67,200–71,650 lbs
Payload	26,980–29,070 kg	59,484–64,090 lbs
Tare	3,430–3,920 kg	7,560–8,640 lbs

NOTE: The dimensions and door openings of all containers correspond to ISO standards. However, due to production tolerances, a difference in measurement is possible.

DISCLAIMER: Every effort is made to ensure this information is accurate, however Triton does not assume any liability for the accuracy of the information and content provided in marketing or information materials, or for the consequences resulting from using the information and content provided. Triton does not guarantee or claim that said information and content is exhaustive. Claims as to the exhaustive nature of said information and content are excluded. The information and content is only provided for advertising purposes and is non-binding. No explicit or implied warranties or guarantees are made. The container displayed only represents a sample of the entire fleet.

The following items are registered or unregistered service marks in the United States and/or foreign jurisdictions pursuant to applicable intellectual property law and are the property of Triton International Limited and its subsidiaries: Triton® and TAL®.



CLASSIFICATION

Lease

Available via Triton's global network of supply locations.

40ft High Cube Dry Container



FEATURES

- Additional height provides extra internal cubic capacity, which means greater interior stacking capacity for your goods
- Manufactured with rust resistant corten steel
- Superior paint systems
- Resistant to damage and corrosion
- Secure and weatherproof, with vents to allow airflow
- Incredibly versatile
- Triton's industry leading new production testing and inspection criteria ensures the highest quality container
- Backed up by Triton's global network of supply locations and dedicated leasing and support teams
- Available globally
- IICL-6 repair criteria saves cost at off-hire
- Damage Protection Plan available to reduce costs and time at off-hire
- Flexible lease terms to meet your company needs

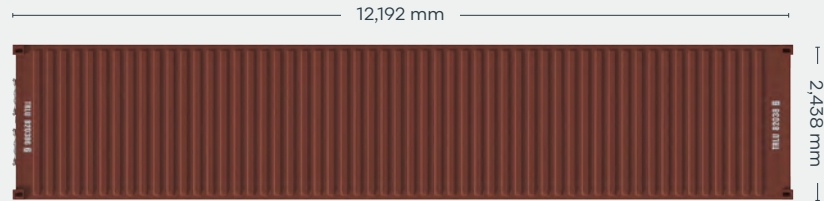

CONTAINER ROOF



CONTAINER FRONT

CONTAINER SIDE

CONTAINER REAR

DIMENSIONS (METRIC/IMPERIAL)

EXTERNAL DIMENSIONS

Length	12,192 mm	40' 0.0"
Width	2,438 mm	8' 0.0"
Height	2,896 mm	9' 6.0"

INTERNAL DIMENSIONS

Length	12,032 mm	39' 5.7"
Width	2,352 mm	7' 8.6"
Height	2,698 mm	8' 10.2"

DOOR OPENING

Width	2,340 mm	7' 8.1"
Height	2,585 mm	8' 5.8"

CAPACITY & WEIGHTS

Inside Cubic Capacity	76.4 m ³	2,700 ft ³
Max Gross	32,500 kg	71,650 lbs
Payload	28,800 kg	63,490 lbs
Tare	3,700 kg	8,160 lbs

NOTE: The dimensions and door openings of all containers correspond to ISO standards. However, due to production tolerances, a difference in measurement is possible.

DISCLAIMER: Every effort is made to ensure this information is accurate, however Triton does not assume any liability for the accuracy of the information and content provided in marketing or information materials, or for the consequences resulting from using the information and content provided. Triton does not guarantee or claim that said information and content is exhaustive. Claims as to the exhaustive nature of said information and content are excluded. The information and content is only provided for advertising purposes and is non-binding. No explicit or implied warranties or guarantees are made. The container displayed only represents a sample of the entire fleet.

The following items are registered or unregistered service marks in the United States and/or foreign jurisdictions pursuant to applicable intellectual property law and are the property of Triton International Limited and its subsidiaries: Triton® and TAL®.



45ft High Cube Pallet Wide Dry Container



CLASSIFICATION

Lease

Available via Triton's global network of supply locations.

FEATURES

- It's distinctive shape allows for loading of 33 Euro Pallets, making it very competitive for Intermodal usage
- Low tare weight
- Fully intermodal: interchangeable on road, rail and sea
- The environment-friendly alternative to road transport (less CO₂ emission)
- Additional height and length provides extra internal cubic capacity, with a greater interior stacking capacity for your goods compared to a standard ISO container
- Manufactured with rust resistant corten steel
- Secure and weatherproof, with vents to allow airflow
- Strong steel construction to protect for impact damages
- Superior paint systems to protect from sea water and other environmental exposure
- Triton's industry leading new production testing and inspection criteria ensures the highest quality container
- Backed up by Triton's global network of supply locations and dedicated leasing and support teams

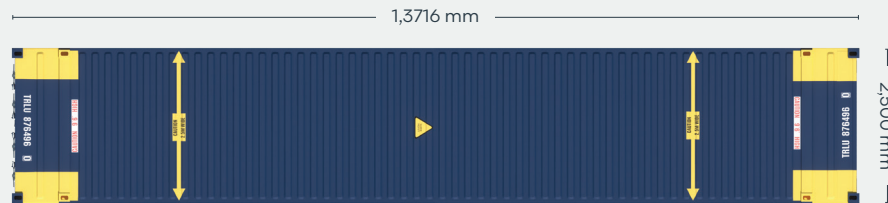

CONTAINER ROOF

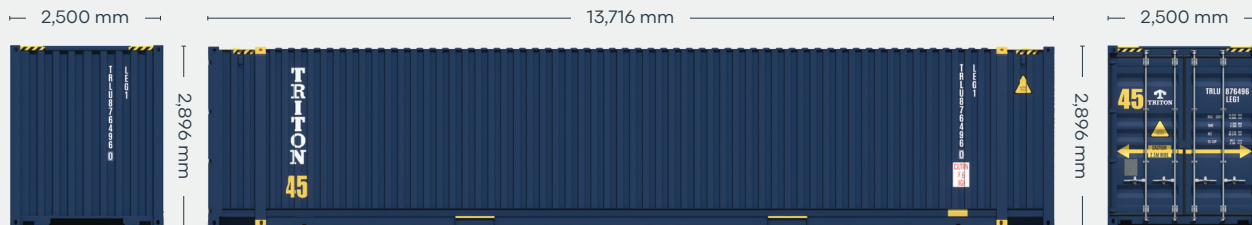

CONTAINER FRONT

CONTAINER SIDE

CONTAINER REAR

DIMENSIONS (METRIC/IMPERIAL)

EXTERNAL DIMENSIONS

Length	13,716 mm	45' 0.0"
Width	2,500 mm	8' 2.4"
Height	2,896 mm	9' 6.0"

DOOR OPENING

Width	2,416 mm	7' 11.1"
Height	2,638 mm	8' 7.0"

INTERNAL DIMENSIONS

Length	13,555 mm	44' 5.7"
Width (Between side panels)	2,444 mm	8' 0.2"
Height	2,695 mm	8' 10.1"

CAPACITY & WEIGHTS

Inside Cubic Capacity	89.3 m ³	3,154 ft ³
Max Gross	34,000 kg	74,960 lbs
Payload	29,550 kg	65,150 lbs
Tare	4,450 kg	9,810 lbs

NOTE: The dimensions and door openings of all containers correspond to ISO standards. However, due to production tolerances, a difference in measurement is possible.

DISCLAIMER: Every effort is made to ensure this information is accurate, however Triton does not assume any liability for the accuracy of the information and content provided in marketing or information materials, or for the consequences resulting from using the information and content provided. Triton does not guarantee or claim that said information and content is exhaustive. Claims as to the exhaustive nature of said information and content are excluded. The information and content is only provided for advertising purposes and is non-binding. No explicit or implied warranties or guarantees are made. The container displayed only represents a sample of the entire fleet.

The following items are registered or unregistered service marks in the United States and/or foreign jurisdictions pursuant to applicable intellectual property law and are the property of Triton International Limited and its subsidiaries: Triton® and TAL®.



CLASSIFICATION

Lease

Available via Triton's global network of supply locations.

Carrier RG15 – Series 55 Clip On



FEATURES

- Ultra-high-efficiency generator enables full power for ISO reefers
- Simple, robust design with familiar operations and maintenance
- Compatible with all reefer machinery manufacturers
- Industry standard, proven 2.2-litre 18.5 KW diesel engine style. EU Stage V compliant, with electronic governor
- CE option included
- 455 litre fuel tank built into all-steel frame
- Standard implementation of enhanced FuelWise™ functionality, a fuel-saving technology that automatically switches the generator set between two speeds via a simple black box controller
- Reduced fuel consumption extends range of distances traveled and reduces carbon footprint
- Pin-mount system with clamp provision (clamp option). For easy attachment and detachment from container box
- Frame and sheet metal components powder-coated for durability and superior corrosion protection
- Carrier full-flow spin-on oil filter with internal bypass filtration
- Integral fuel filter with water separator
- High-efficiency air cleaner
- 12V DC maintenance-free battery and solid state battery charger
- **NEW!** Track and Trace options available

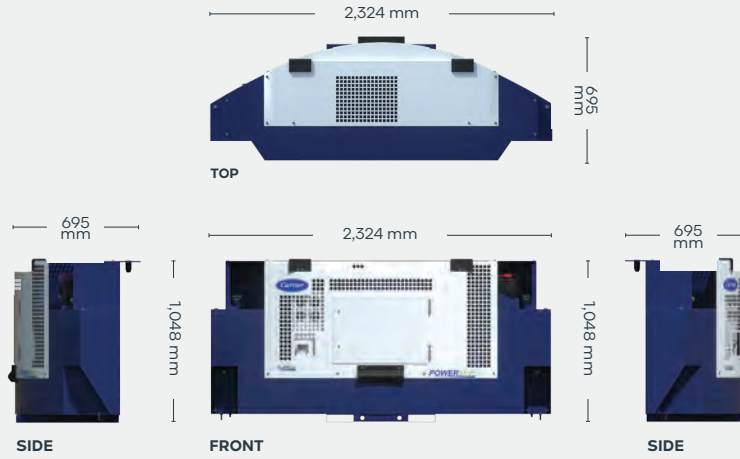

DIMENSIONS (METRIC/IMPERIAL) & SPECIFICATIONS

EXTERNAL DIMENSIONS

Length	2,324 mm	7' 7.5"
Width	695 mm	2' 3.4"
Height	1,048 mm	3' 5.2"

ENGINE

V2203L-DI-E4B, 4-cylinder, water-cooled, 2.2 litre direct-injection diesel engine

FUEL TYPE & CAPACITY

Fuel Type	Diesel	
Fuel Tank	455 liter	120 gal

BATTERY

Type	12V DC maintenance-free battery
-------------	---------------------------------

APPROXIMATE WEIGHT

Less fuel	875 kg
------------------	--------

NOTE: The dimensions and door openings of all containers correspond to ISO standards. However, due to production tolerances, a difference in measurement is possible.

DISCLAIMER: Every effort is made to ensure this information is accurate, however Triton does not assume any liability for the accuracy of the information and content provided in marketing or information materials, or for the consequences resulting from using the information and content provided. Triton does not guarantee or claim that said information and content is exhaustive. Claims as to the exhaustive nature of said information and content are excluded. The information and content is only provided for advertising purposes and is non-binding. No explicit or implied warranties or guarantees are made. The container displayed only represents a sample of the entire fleet.

The following items are registered or unregistered service marks in the United States and/or foreign jurisdictions pursuant to applicable intellectual property law and are the property of Triton International Limited and its subsidiaries: Triton® and TAL®.



CLASSIFICATION

Lease

Available via Triton's global network of supply locations.

Thermo King SG-5000 Clip On



FEATURES

- Ensure total product protection, time after time
- The intelligent controls system allows both quick local diagnostic and full monitoring over telematics
- Compatible with all reefer machinery manufacturers
- Proven reliability and durability
- Exceed the power requirements for any ISO reefer
- Surpasses all North American emission compliance requirements including: EPA, CARB, Environment Canada and EEA
- Auto restart
- Built to last and perform – lowest total cost of ownership (TCO)
- Automated pre-trip testing
- Data logging of events, alarms and messages
- Delivered in both undermount and clip-on design
- Eco power with two speed technology
- Pin-mount system with clamp provision (clamp option). For easy attachment and detachment from container box
- **NEW!** Track and Trace options available

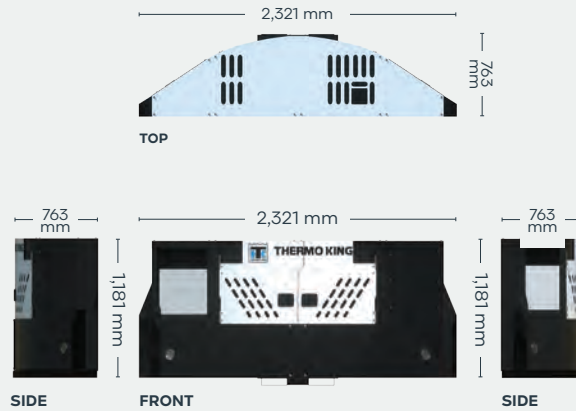

DIMENSIONS (METRIC/IMPERIAL) & SPECIFICATIONS

EXTERNAL DIMENSIONS

Length	2,321 mm	7' 7.3"
Width	763 mm	2' 6.0"
Height	1,181 mm	3' 10.5"

ENGINE

Thermo King diesel engine compliant with EPA Tier 4 and CARB regulations

FUEL TYPE

No. 2 diesel (under normal conditions)
No. 1 diesel (cold weather fuel)

SPEED & POWER

Rotational Speed	1500 ±25rpm / 1800 ±25rpm
Generator Output	460/230Vac, 3Phase, 60Hz
Power Apparent	15kW
Power Rotational	18.75 kVA
Speed	1800rpm
Electrical System	SG+ microprocessor controller
Battery	12V, 925CCA

FUEL TANK Included in all models

SGCO	473 litres	125gal
SGCM	302l or 198l	80gal or 50gal
SGSM	302l or 198l	80gal or 50gal

WEIGHT - LESS FUEL

SGCO	871kg	1920lbs
SGCM		
50gal tank	653kg	1440lbs
80gal tank	680kg	1500lbs

NOTE: The dimensions and door openings of all containers correspond to ISO standards. However, due to production tolerances, a difference in measurement is possible.

DISCLAIMER: Every effort is made to ensure this information is accurate, however Triton does not assume any liability for the accuracy of the information and content provided in marketing or information materials, or for the consequences resulting from using the information and content provided. Triton does not guarantee or claim that said information and content is exhaustive. Claims as to the exhaustive nature of said information and content are excluded. The information and content is only provided for advertising purposes and is non-binding. No explicit or implied warranties or guarantees are made. The container displayed only represents a sample of the entire fleet.

The following items are registered or unregistered service marks in the United States and/or foreign jurisdictions pursuant to applicable intellectual property law and are the property of Triton International Limited and its subsidiaries: Triton® and TAL®.



HERE. THERE. EVERYWHERE

We supply the world

Triton is the largest lessor of intermodal containers in the world with over 7 million TEU of containers. Our services are available in 89 countries around the globe. So, no matter where you need containers, we'll have them nearby. To find your nearest Triton Container Sales manager visit www.tritoncontainer.com.



**Global inventory of
cargoworthy containers
for lease and sale.**



**Unrivalled container
supply at competitive
prices.**



**Outstanding and
highly responsive
customer services.**



**Global network of 20 offices
and 3 independent agencies
across 16 countries.**



**Equipment
built to the
highest quality.**



**Our size, strength and reliability
make us the go-to supplier of
intermodal shipping containers.**



TRITON

We're the biggest for a reason, contact our friendly experts and experience Triton's world-leading service and cost savings today. Imagine what we can do together.

www.tritoncontainer.com